



Operating Manual

Thermoelectric Heat Flux Sensors

HFD03 SERIES

2019

Release 1.0

Edition February 2019

Copyright

All rights reserved.

Reproduction in any manner, in whole or in part is straightly prohibited without written permission of PL ENGINEERING Ltd.

The information contained in this document is the subject to change without notice.

Limited Warranty

PL ENGINEERING Ltd. warrants that the Thermoelectric Heat Flux Sensor of HF03 Series, if properly installed and used, will be free of defects in material and workmanship and will substantially conform to PL ENGINEERING’s publicly available specification for a period of one (1) year after the date that the Thermoelectric Heat Flux Sensor of HF03 Series was purchased.

If the Thermoelectric Heat Flux Sensor of HF03 Series, which is the subject of this Limited Warranty, fails during the warranty period for the reasons covered by this Limited Warranty, PL ENGINEERING, at this option, will:

REPAIR the Thermoelectric Heat Flux Sensor of HF03 Series; OR REPLACE the Thermoelectric Heat Flux Sensor of HF03 Series with another unit of the same model.

Trademark Acknowledgments

All trademarks are the property of their respective owners.

PL Engineering Ltd.
46 Warshavskoe shosse, Moscow
115230 Russia
phone: +7-499-678-32-31
e-mail: info@promln.com
www.promln.com

European office: **TEC Microsystems GmbH**
Schwarzschildstr. 8, 12489 Berlin,
Germany
phone +49 (030)6789 3314
e-mail info@tec-microsystems.com
www.tec-microsystems.com

CONTENT

1.	INTRODUCTION	7
	<i>Features</i>	7
2.	SPECIFICATIONS	8
	<i>Numbering system</i>	9
3.	QUICK START	10
3.1	About Heat Sensor HF03 series	10
3.2	Preparations for working	10
3.3	Sensor testing	11
3.4	Sensor calibration	11
3.5	Mounting of the Sensor	11
3.6	Data acquisition	12
3.7	How to calculate heat flux	12
3.8	Sensors service	12
4.	HEAT FLUX SENSORS INTRODUCTION	13
4.1	Description of installation	13
4.2	Sides of the Sensor	13
5.	FUNCTIONALITY TEST	14
5.1	Checking of AC Resistance	14
5.2	Checking of Figure-of-Merit.	14
5.3	Checking of Sensor behavior	15
6.	INSTALLATION OF SENSORS	16
6.1	Mounting substances	16
	<i>Adhesive tape</i>	16
	<i>Thermally conductive paste</i>	16
	<i>Thermally conductive glue</i>	16
6.2	Removal of the mounting substance	17
6.3	Mounting methods	17
	<i>At the interface between a solid surface and gas</i>	17
	<i>Between two solid materials</i>	18

7.	DATA ACQUISITION	20
7.1	Datalogger DX8140	20
	<i>Applicability</i>	20
7.2	Voltmeter as a read-out device	20
	<i>Applicability</i>	21
7.3	Third party read-out device	21
	<i>Applicability</i>	21
8.	DATA ANALYSIS	22
8.1	Temperature corrections	22
	<i>Example for calculating</i>	24
8.2	Heat flux measurements	25
	<i>Example for heat flux measurement</i>	25
9.	SELF-CALIBRATION PROCEDURE	27
9.1	Method	27
9.2	Measurement Scheme	28
9.3	Equipment	28
9.4	Example	29
10.	MAINTENANCE OF THE SENSOR	30
10.1	Removing Sensor from measurement setup	30
10.2	Cleaning of Sensor	30
10.3	Storage	30
11.	ADDITIONAL INFORMATION	31
11.1	Electromagnetic field	31
11.2	Trouble shooting electrical problem	31
11.3	Application in temperatures outside of calibration range	31
11.4	Influence of radiative heat flux	31
11.5	Use in fluids	31
12.	DEFINITIONS	33





1. INTRODUCTION

Heat Flux Sensors of HF03 series – the series of high sensitive and self-calibrating miniature sensors for conductive, convective and radiation heat fluxes.

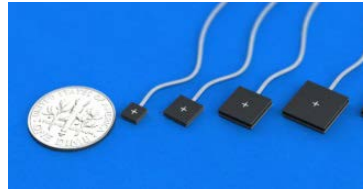

Features

- *High sensitivity*
- *Miniature design*
- *Self-calibrating concept*
- *Miniature FET cable and connector (optional)*
- *A range of customized dimensions is available*

The Sensors are developed as a series of a range of sizes: 7x7, 12x12, 17x17 and 22x22 mm². Optional dimensions (size and thickness) as well as customized performance parameters are available on request.

The Sensors were developed for measurement of conductive, convective and radiation heat fluxes in a wide range of heat flux intensities. The high sensitivity of the Sensors of the series provides accurate experiments and data on objects of investigations.

One of the feature of the Sensors is the self-calibration method (patent pending RU2014145948 dated 17.11.2014). It means possibility to calibrate precisely the Sensor by measurement of its thermoelectric performance parameters. It is not necessary to remove it and send to labs.

The calibration procedure is possible with use of PL ENGINEERING Datalogger of the DX8140 series, specially developed for thermoelectric Heat Flux Sensors, or by use of PL ENGINEERING Z-meters. The calibration procedure is described in Chapter 10.

2. SPECIFICATIONS

Product name	Units	HFD03-032-05L07	HFD03-128-05L12	HFD03-288-05L17	HFD03-512-08L22
Detector Type		Thermoelectric			
Surface material		Aluminum, painted black			
Protection ²⁾		IP67			
Surface dimensions AxB	mm ²	7	12	17	22
Sensing area	mm ²	49	144	289	484
Thickness H	mm	2.3	2.3	2.3	2.3
Pellet pairs		32	128	288	512
Sensitivity S _e	μV/W/m ²	25	95	210	375
Integral sensitivity S _a	V/W	0.56	0.66	0.74	0.78
Heat Flux Range P _e , ±	W/m ²	4 500	5 000	5 500	5 500
Integral Heat Flux P _a , ±	W	0.2	0.8	1.6	2.7
Thermal Time Constant τ	s	2.6	2.4	2.2	2.2
Thermal Resistance R _T	K/W/m ²	2.09E-03	1.82E-03	1.81E-03	1.79E-03
Integral Thermal Resistance R _T	K/W	42.7	12.6	6.3	3.7
Electrical Resistance ACR	Ohm	3.6	14.2	32.0	56.9
Temperature Dependence ³⁾ dS/dT	%/°C	0.25	0.25	0.25	0.25
Linearity with Power dS/dP, ±	%/W/m ²	5.23E-04	4.55E-04	4.52E-04	4.47E-04
Homogeneity dS/dA, ±	%	1.0	1.0	1.0	1.0
Calibration Accuracy, ±	%	3.0	3.0	3.0	3.0
Calibration Temperature Range	°C	-40 ... +85	-40 ... +85	-40 ... +85	-40 ... +85
Operating Temperature Range	°C	-50 ... +150	-50 ... +150	-50 ... +150	-50 ... +150
Max. compressive Force for clamping	kg	3	12	26	46
Integrated thermistor		no	no	no	no
Cable ⁴⁾ Length L,	cm	180	180	180	180
Connector ⁵⁾		FMC 0,5/6-ST-2,54-18211355			

Notes:

- 1) Performance data shown in specifications are given for ambient temperature $T_a=300\text{ K}$ ($27\text{ }^\circ\text{C}$)
- 2) Average value. Detailed temperature dependence is given in table
- 3) Sensor is equipped with thin FET cable 1.8 m, standard length.
- 4) Cable is ended (optional) by miniature connector FMC 0,5/6-ST-2,54-18211355. The female part - MCV 0,5/6-G-2,54 SMD R44-1821588

3. NUMBERING SYSTEM

The following numbering system was developed to order thermoelectric Heat Flux Sensors of PL ENGINEERING.

The sensor serial number gives some useful information about design of the sensors.

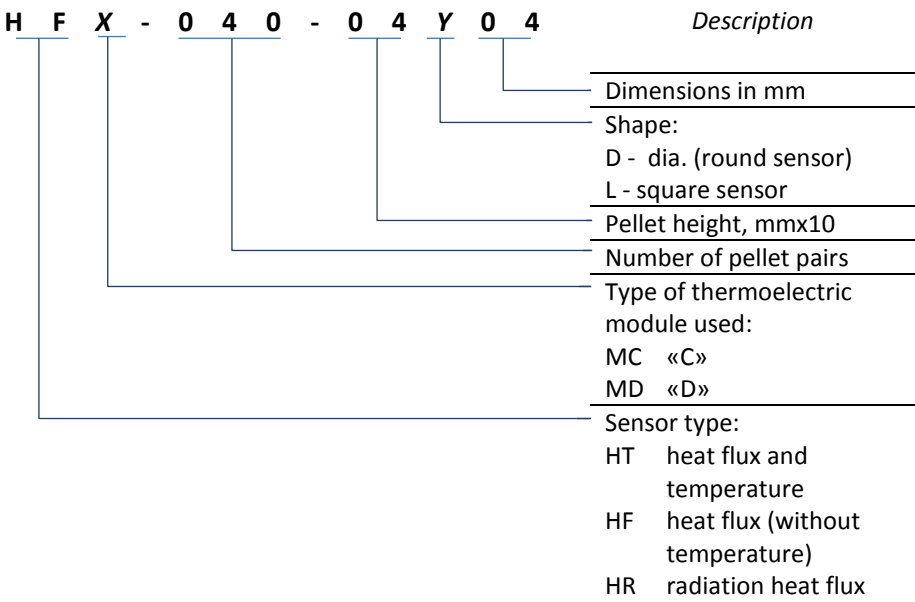

4. QUICK START

4.1 About Heat Sensor HF03 series

The Heat Flux Sensors of the HF03 series – the series of high sensitive and self-calibrating miniature Sensors. The Sensors were developed for measurement of conductive, convective and radiation heat fluxes in a wide range of intensities.

The Sensors have a square shape. Electric connections come from the parts by a miniature FEP Flat Ribbon Cable (0.025" Pitch, 32 AWG). The standard length is 180 cm (6"). The cable output is ended by a six-pin miniature connector of the type DFMC 0,5/ 6-ST-2,54 (Phoenix).

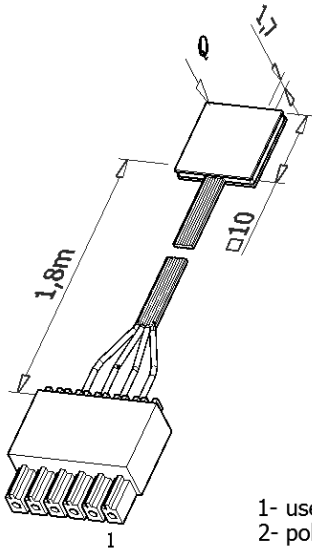

Connector (male)
FMC 0,5/ 6-ST-2,54-1821135



Female
MCV 0,5/ 6-G-2,54 SMD R44-1821588

Pin	Output	Note
1		
2	-Uf	1
3	-Us	2
4	+Us	2
5	+Uf	1
6		

- 1- use for calibration
- 2- polarity as shown heat direction

Both sides of the Sensors are ceramics (AlN) covered with black paint stable for working in wet ambient and even under water.

Internal ambient of the Sensor is potted by a silicon compound of high temperature stability.

4.2 Preparations for working

You need to procure the following for working with the Sensors:

- *Mounting substance (i.e. tape, paste, or glue) to mount the Sensor in your setup.*
- *Read-out device (i.e. PL ENGINEERING DX8140 Datalogger, millivoltmeter), or third party read-out device. Note that the read-out device must have passive input for Sensor.*
- *Device for Sensor self-calibration procedure. If PL ENGINEERING DX8140 Datalogger is procured, the procedure is available. Otherwise any model of PL ENGINEERING Z-meters is suitable for that.*

4.3 Sensor testing

Before mounting the Sensor must be tested as described in Chapter 6.

4.4 Sensor calibration

If necessary, or required for an application the Sensor can be calibrated by the self-calibration procedure described in Chapter 10.

4.5 Mounting of the Sensor

The common mounting scheme is advised in Fig. 4.1

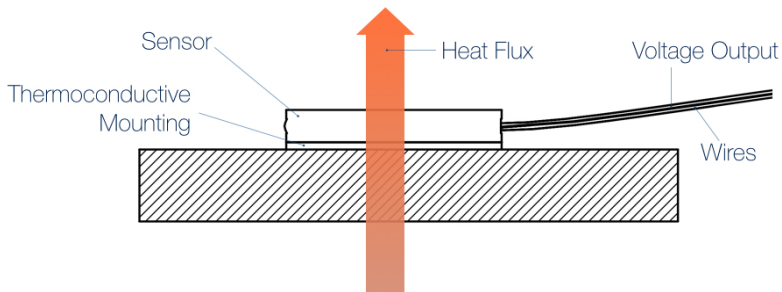

Fig 4.1 Schematic diagram of mounting and functionality of HF03 Heat Flux Sensor.

Ensure that the mounting surface is flat, dry, and free of dust and grease. Clean the Sensor surface with ethanol or isopropanol. Do not use acids or alkali for cleaning the Sensor. Mount the Sensor using a mounting substance. A detailed description of the Sensor mounting is given in Chapter 6.

4.6 Data acquisition

Connect the Sensor to the read-out devices and collect data according to the data acquisition procedure.

4.7 How to calculate heat flux

Every Heat Flux Sensor has performance parameter – sensitivity to heat flux (S_a and S_e). The data acquisition device collects voltage output from the Sensor U .

The heat flux P must be calculated as

$$P = \frac{U}{S_i \times F(T)} \quad (4.1)$$

Where S_i – sensitivity: if $S_i=S_e$, P will be outputted in the units of heat flux density [W/m^2]; if $S_i=S_a$, the integral heat flux will be obtained in [W]; $F(T)$ – temperature correction factor, dependence of sensitivity on working temperature T .

4.8 Sensors service

The service procedures and procedures of removing the Sensors from the setup are described in Chapter 11.

5. HEAT FLUX SENSORS INTRODUCTION

5.1 Description of installation

The Sensor has two flat sides marked differently.

One side of the Sensor is marked by “+” – positive side.

If the Sensor is placed with its positive side to the heat flux (Fig. 5.1), the positive voltage output will be on the Sensor’s wire #3 (Connector pin #4).

In other words if the positive voltage is on Connector pin #4, the heat flux comes from the positive side. And vice versa.

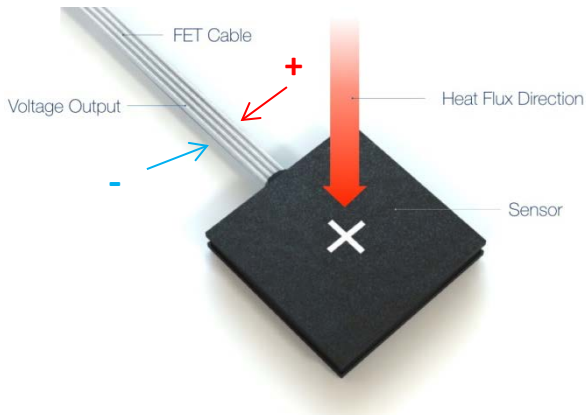

Fig. 5.1 Direction of heat flux.

5.2 Sides of the Sensor

Although the positive side is marked differently, the Sensor can work bi-directionally with the same performance. Only the direction of the output voltage will give information about the direction of the heat flux.

But in the application it is simple to follow the rule – heat comes to the positive side.

6. FUNCTIONALITY TEST

All the HF03 thermoelectric Heat Flux Sensors adhere to high manufacturing standards. Before shipping, the performance of each Heat Flux Sensor is individually checked and calibrated. All the data are advised in Specifications of the Sensor.

However, external factors (e.g. transportation, prior use), may affect the functionality of the Sensor module. Before the permanent installation, the Sensor functionality must be tested.

6.1 Checking of AC Resistance

The electrical resistance testing is done using a standard multimeter via a four-wire probe measurement. The resistance measurement must be done without any applied temperature gradient (e.g. with the Sensor hanging in air holding it at the cables).

The resistance must be in the range specified in the Sensor's respective datasheet. This value does not include the resistance of the cables.

Resistance below 0.1 ohm indicates a short circuit, while resistance higher than the value stated in the datasheet indicates physical wearout of the Sensor and/or its cables. In both cases, the Sensor is not functional and must be replaced.

6.2 Checking of Figure-of-Merit.

The Sensor is a thermoelectric module device. Performance and functionality of the Sensor can be examined by two parameters: the AC Resistance (see above) and Figure-of-Merit. In some cases functionality checking only by AC resistance measurements is not enough. Particularly in the case of probable failure, and necessity to investigate reasons of this.

Checking of Z together with ACR gives much more information about functionality of the thermoelectric Sensor.

Checking of the Figure-of-Merit requires a special device – Z-Meter. DX8140 Datalogger. It has a special function of Figure-of-Merit checking.

Contact PL ENGINEERING for the devices and checking. And visit PL ENGINEERING website for more literature on checking of Figure-of-Merit of thermoelectric modules

<http://www.promIn.com/technology/publications/>

The specification of every Sensor contains Z measured at vendor factory before shipment.

6.3 Checking of Sensor behavior

Connect the Sensor to a voltmeter (resolution preferably in the 0.1mV range). Place the Sensor on a metallic surface at room temperature. When touching the Sensor with a warm finger on the upper surface, you should get a signal in the mV range.

A Sensor signal below 0.1 mV indicates a short circuit. Check whether the resistance of the Sensor is > 0.1 ohm as described above.

If the signal randomly fluctuates between a positive and negative signal, or the voltage is in the ± 1 V range, you may have an open circuit. Check the connection of your electrical probes.

If the signal shows one of the three described features above, the Sensor is not functional and has to be replaced.

In this case, please contact the vendor.

7. INSTALLATION OF SENSORS

7.1 *Mounting substances*

In order to obtain meaningful measurement data, the HF03 Heat Flux Sensor has to be mounted with adequate mounting substances. Adequate mounting substances features are high thermal conductivity and low thickness. Three types of mounting substance are suitable: adhesive tape, thermally conductive paste, and thermally conductive glue.

The mounting substance should be chosen based on the measurement setup.

Adhesive tape

Adhesive tape should be used for simple tasks, where quick setup is crucial and the thermal coupling is of secondary importance.

Clean the surface to be measured and apply the tape to the backside of the Sensor. Mount the Sensor onto the surface by applying gentle pressure to establish adhesion. You can add a thermal paste (see the next section) for improving thermal coupling to the surface.

Thermally conductive paste

Thermally conductive paste is recommended in applications where pressure is used to fix the HF03 Heat Flux Sensor in the measurement setup. It generates a very strong thermal coupling as the paste adapts to the surface inhomogeneities.

Clean the surface to be measured and spread a thin layer of paste onto the backside of the Sensor. Then press the Sensor onto the surface. You may need to hold the Sensor in place with tape across the electric cables.

Thermally conductive glue

Thermally conductive glue is suitable for applications where additional mechanical stability is required. Similar to the paste, it generates a strong thermal coupling and adapts to surface inhomogeneities.

Clean the surface to be measured and spread a thin layer of thermal glue onto the backside of the Sensor. Then press the Sensor onto the surface and follow the curing instructions of the glue.

7.2 Removal of the mounting substance

To remove the different mounting substances, refer to the respective manufacturer's instruction manual. If no instructions are available, contact the supplier. Isopropanol and ethanol can be used as cleaning agents whereas acids and alkali must be avoided to avoid damage to the Sensors. Rub the surface gently with a soaked tissue to remove residues of the mounting substance.

7.3 Mounting methods

The Sensor responds to three types of heat transfer: conduction, convection and radiation. The Sensors are fully calibrated for measuring conductive heat flux. The conductive calibration ensures highly precise measurements for the following two measurement scenarios.

At the interface between a solid surface and gas

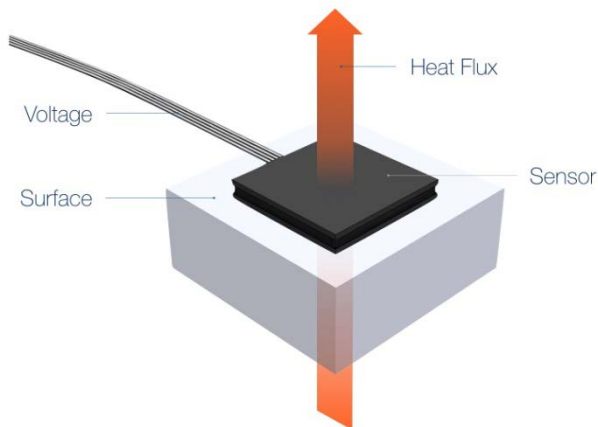

Fig. 7.1 Mounting onto solid surface

Mounting instructions:

1. *Select a representative area of the surface you want to study.*
2. *Ensure that the area of interest is flat, dry, and free of dust and grease. Clean the Sensor surface with ethanol or isopropanol. Do not use acids or alkali for cleaning the Sensor.*
3. *Apply the Sensor using any of the above described mounting substances. When mounting the Sensor, make sure no air is trapped between the surface and the Sensor. Air gaps are thermally insulating and heavily distort the measurement results.*
4. *Mount the Sensor with the positive side of the Sensor in the direction of the expected positive heat flux (as described in Section 5.1).*

Do not apply more than 200 N per cm² of compressive force to the Sensor at any time.

5. In order to ensure meaningful results, we recommend making the exposed Sensor surface similar to the finish of the surface to be measured. For example, if the surface to be measured is covered with white paint, you will get maximum accuracy by painting the Sensor surface with the same paint.

Between two solid materials

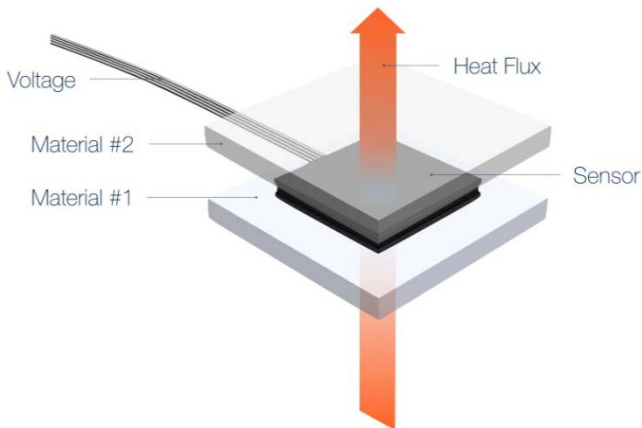

Fig. 7.2 Mounting between two solid materials

Mounting instructions:

- 1. Ensure that both solid bodies have contact areas at least as large as the HF03 Heat Flux Sensor.*
- 2. Ensure that the two solid planes are perfectly parallel to each other and that the contact surfaces are flat, dry and free of dust and grease. Clean the Sensor surface with ethanol or isopropanol. Do not use acids or alkali for cleaning the Sensor.*
- 3. Mount the Sensor with the positive side of the Sensor in the direction of the expected positive heat flux.*
- 4. Sandwich the Sensor between the two contact areas using any of the above described mounting substances. It is highly recommended to use thermally conductive paste or glue to increase the quality of the thermal contacts between the surfaces and the Sensor.*

Do not use too much thermal paste or glue as it increases the risk of thermal short-cuts between the two contact surfaces. Furthermore, ensure that no air is trapped between the surface and the Sensor. Air gaps are thermally insulating and heavily distort measurement results.

- 5. A clamping force of 10N - 100N per cm² is recommended in order to optimize the thermal contact. The maximal value of 200N per cm² should not be exceeded at any time.*

8. DATA ACQUISITION

The HF03 Heat Flux Sensors' output is an analog voltage signal. Depending on the measurement task, the voltage signal can be in the μV to mV range.

To read-out the Sensor signal, three options are available: the DX8140 Datalogger, a voltmeter, or a third party read-out device. The following section describes each option separately.

8.1 Datalogger DX8140

The DX8140 Datalogger is specifically developed for reliable and straightforward heat flux measurements in combination with the HF03 and HF03 Heat Flux Sensors. The DX8140 Datalogger works as a complete solution with included software. The DX8140 Datalogger can be set to measure either an analog voltage signal (in mV) or heat flux signal (in W/m^2). Please follow the Instruction Manual, which is available for the DX8140 Datalogger.

Applicability

The DX8140 Datalogger is compatible with all HF03 Heat Flux Sensors with a plug.

8.2 Voltmeter as a read-out device

Voltmeters are used for simple measurement tasks and/or for Sensor functionality tests. In order to read the output voltage of the Sensor with high accuracy, you need a voltmeter with high resolution. The resolution of the heat flux measurement is limited by the voltmeter resolution and noise. Table 1 demonstrates the relevance of voltmeter resolution.

The voltmeter resolution is the most critical feature when choosing the optimal device. Due to the low electrical resistance of the Sensor, there are no special requirements regarding the input resistance of the voltmeter.

All the HF03 Heat Flux Sensors can be used bi-directionally. If the direction of the heat flux is reversed, the sign of the Sensor voltage output changes (i.e. from positive to negative). Since the sensitivity of the Sensor does not

depend on the direction of the heat flux, the measurement of the reversed heat flux has the same accuracy.

Table 8.1: Heat flux resolution of Heat Flux Sensors of HF03 series at different voltmeter resolution (1 mV and 1 μ V)

Sensor type	Sensitivity, μ V/(W/m ²)	Heat flux resolution W/m ²	
		Voltmeter 1mV	Voltmeter 1 μ V
HTD03-032-05D09	40	25.0	0.025
HTD03-128-05D16	145	6.9	0.007
HTD03-288-05D20	335	3.0	0.003
HTD03-512-08D25	555	1.8	0.002

However, on some voltmeters the measurement of negative voltages may not be possible or may be less accurate than the measurement of positive voltages. Further information about the positive and negative sides of the Sensors can be found in Section 4.

Applicability

Voltmeters are compatible with all the HF03 Heat Flux Sensors without a plug.

8.3 Third party read-out device

A data logger is highly recommended for the measurement of time-dependent variations of the Sensor signal. For the choice of a suitable device, apply the same considerations as for the voltmeter.

Applicability

Third party read-out devices are compatible with all the HF03 Heat Flux Sensors without a plug.

9. DATA ANALYSIS

This section contains the basic analysis methods needed to interpret data from the HF03 and HF03 Heat Flux Sensors. All the information necessary for it can be found in the following documents:

- *Specifications*. The Specification is delivered with every Heat Flux Sensor for R&D Applications. It contains the Sensor sensitivity Se_0 [$\mu\text{V}/(\text{W}/\text{m}^2)$] and integral sensitivity Sa_0 [V/W] at calibration “standard” temperature T_0 , and all correction factors that are needed to increase accuracy of the results.
- *Datasheet*. The datasheet provides an overview for all technical parameters of HF03 Heat Flux Sensor. It also states the Sensor area, which is necessary for calculating heat flux.

9.1 Temperature corrections

The sensitivity of the thermoelectric Heat Flux Sensors depends on the temperature at which they are used. For thermoelectric Heat Flux Sensors of the HF03 series averaged temperature dependence of $0.25\%/^{\circ}\text{C}$ is given in the Specifications and Datasheets (Table 9.1). The standard calibrated Sensitivity is given in the specification at temperature 300K (27°C) which is selected as “standard”.

Thus, if using the Sensors at temperatures below or above 300K (27°C), with every degree of Centigrade accuracy becomes worse by $0.2\text{-}0.25\%$ per degree.

For temperature range close to the “standard” temperature, i.e. $\pm 1^{\circ}\text{C}$, the inaccuracy of the measurements in the general case is negligible – about $\pm 1\%$.

But for a wider range of temperatures and for precise measurements the temperature corrections are recommended.

It is easy to obtain them as for all thermoelectric Heat Flux Sensors of PL ENGINEERING the temperature dependences are investigated and general formulas are advised in the Specifications and Datasheets.

The temperature dependence of sensitivity is given as a polynomial of the 3-rd order:

$$Sa = Sa_0 \times [(A_2 \times (T - T_0)^2 + A_1 \times (T - T_0) + A_0)] \quad (9.1)$$

where A_0 - is always =1; Sa_0 - sensitivity at “standard” calibration temperature T_0 (= 300K); Sa - sensitivity at working temperature T .

In the expression (9.1) value in brackets is a temperature correction factor.

$$F(T) = [(A_2 \times (T - T_0)^2 + A_1 \times (T - T_0) + A_0)] \quad (9.2)$$

The sensitivity Se [$\mu\text{V}/(\text{W}/\text{m}^2)$] is also given in the Sensor Specification (Chapter 3. Specifications) and it correlates with the integral sensitivity Sa [V/W] as

$$Se = Sa \times S \quad (9.3)$$

where S – sensitive surface of the Heat Flux Sensor.

Thus the temperature correction factor $F(T)$ is the same for both sensitivities

$$Sa = Sa_0 \times F(T) \quad (9.4)$$

$$Se = Se_0 \times F(T) \quad (9.5)$$

The coefficients of the polynomial expression are common and are given in the Datasheet of the Heat Flux Sensor series (table 2).

Table 9.1. Polynomial expression of temperature dependence of Sensors sensitivity

Sensor series	A0	A1	A2	dS/dT, %	Ta, K
HF03	1	2,299E-03	-2,094 E-05	0,25	300
Temperature range of calibration -40...+80 °C					
Common formula					
$Sa = Sa_0 \times [(A_2 \times (T - T_0)^2 + A_1 \times (T - T_0) + A_0)]$					

Thus, to obtain the temperature correction, you need to know average temperature T of measurement.

If a Heat Flux Sensor without an integrated thermistor Sensor is used (the HF03 and HRX series) you need to apply an external temperature Sensor.

If T is not measured, it can be approximated by the following formula:

$$T = \frac{T_h + T_c}{2} \quad (9.6)$$

where T_h and T_c are the respective temperatures of the hot and the cold sides of the Sensor.

Typically, the difference between T_h and T_c is small. If the Sensor is mounted onto the hot surface, T is better approximated by $T = T_h$.

Example for calculating

The Sensor type HFD03-128-05L12 was taken for measurements.

The Sensor is mounted on a warm (hot) surface and is exposed to air. The surface has a temperature of 50°C, which is a good approximation for T (see the last section).

The following Sensor parameters are given in its specification (Chapter 3. Specifications):

$$S_e = 90 \mu\text{V}/(\text{W}/\text{m}^2)$$

$$S_a = 0.64 \text{ V}/\text{W}$$

$$dS/dT = 0.25\%/^\circ\text{C}$$

$$T_o = 27^\circ\text{C}$$

The temperature correction factors are the following:

- With use of averaged dS/dT ($=0.25\%/^\circ\text{C}$)

$$F(T) = 1 + \frac{\partial S}{\partial T} \times (T - T_o) = 1 + 0.25 \times (50 - 27) = 1 + 5.8\% = 1,058 \quad (9.7)$$

- *More precise correction by polynomial expression (9.2) with given coefficients (table 9.1) gives the following:*

$$\begin{aligned}
 F(T) &= [(A_2 \times (T - T_0)^2 + A_1 \times (T - T_0) + A_0)] \\
 &= [-2,094 \times 10^{-5} \times 23^2 + 2,299 \times 10^{-3} \times 23 + 1] \quad (9.8) \\
 &= [-0.011077 + 0.052877 + 1] = 1,063
 \end{aligned}$$

The polynomial expression gives a more precise correction factor which is slightly differing from the rough averaged value.

Thus, if possible, we recommend using the Polynomial expression rather than an averaged value given in the Specification only as a indicator value.

But for rough estimations the averaged value $\frac{\partial S}{\partial T}$ is quite enough.

9.2 Heat flux measurements

The DX8140 Datalogger, a voltmeter, or a third party read-out device measures and stores (Datalogger) an analog output in voltage units U (V, mV, μ V) .

The heat flux P is calculated with use of sensitivity and calculated correction factor (theabove section) F(T). Depending on the sensitivity units mV/(W/m²) (Se) or V/W (Sa) the density of heat flux W/m² (Ps) or total heat flux W (Pa) will be calculated as

$$Pe = \frac{U}{Se \times F(T)} \quad (9.9)$$

$$Pa = \frac{U}{Sa \times F(T)} \quad (9.10)$$

Example for heat flux measurement

The same Sensor type HFD03-128-05L12 (the above section) at the temperature 50°C with a given sensitivity and calculated correction factor (9.6) measures the following:

Voltage U = 320 μ V

Heat flux is the following

$$Pe = \frac{U}{Se \times F(T)} = \frac{320}{90 \times 1,063} = 3.3 \text{ W/m}^2 \quad (9.11)$$

$$Pa = \frac{U}{Sa \times F(T)} = \frac{320 \times 10^{-6}}{0.64 \times 1,063} = 0.301 \times 10^{-3} \text{ W} = 0.301 \text{ mW} \quad (9.12)$$

10. SELF-CALIBRATION PROCEDURE

10.1 Method

Sensitivity of thermoelectric Heat Flux Sensor **Sa**:

$$Sa = \frac{U}{P\alpha} = N \times a \times R_T \quad (10.1)$$

where **U_α** – Sensor signal at total heat flux **Pα**; **N** – number of thermoelement pairs in the Sensor; **S** – sensitive surface area; **R_T** – thermal resistance of Sensor ; **α** – averaged Seebeck coefficient for pair of n- and p-type thermoelements.

Figure-of Merit **Z** of thermoelectric Sensor

$$Z = \frac{(N \times a)^2 \times R_T}{ACR} \quad (10.2)$$

where **ACR** – AC resistance of the heat fux Sensor.

The calibration expression with use of **Z**, **ACR** and Seebeck coefficient **α** are the following

$$Sa = \frac{1}{a \times N} Z \times ACR \quad (10.3)$$

$$Se = Sa \times S = \frac{S}{a \times N} Z \times ACR \quad (10.4)$$

where **S** – sensitive surface area.

Thus, according to the formulas (10.3-10.4) the sensitivity calibration of the thermoelectric Heat Flux Sensor is available with use:

- Construction parameters of the Sensor: number of pellets pairs **N**; and size of sensitive surface **S**. The parameters are given in datasheets and Specifications (Chapter 3. Specifications);
- Property of thermoelectric material of the Sensor **α** (Seebeck coefficient). This parameter measured at standard temperature is given in the Sensor Specification. Moreover, temperature

dependence of the parameter is also given in Specifications and datasheets (Table 10.1).

- Measurement of Figure-of-Merit Z and AC Resistance ACR of the Sensor. The measurements can be done with use of DX8140 Datalogger or Z-meters of PL ENGINEERING, any model.

That is really a self-calibration method as it does not require any external heat source. And it can be done at the user setup.

Table 10.1 Averaged (for pair of n- and p-types pellets) Seebeck coefficient of thermoelectric Sensors

Typical a_0 , $\mu\text{KB/K}$	A0	A1	A2	A3	T_0 , K
410	1	+1,291E-03	-8,647-06	+7,843E-08	300
Temperature range -40...+80 °C					
Common formula					
$\alpha_T = \alpha_{T_0} \times [(A_2 \times (T - T_0)^2 + A_1 \times (T - T_0) + A_0)]$					

10.2 Measurement Scheme

The self-calibration is made by measurement of Figure-of-Merit and ACR resistance of thermoelectric Heat Flux Sensor by the four-wire method which is provided by four wires of the FET cable connected to the Sensor.

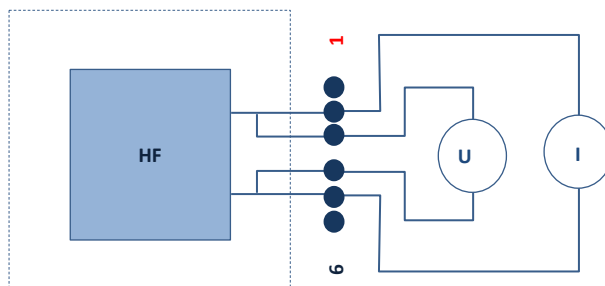

Fig. 10.1 Connection scheme for self-calibration procedure.

10.3 Equipment

Use the series of Z-Meters made by PL ENGINEERING for measurement of Figure-of-Merit and ACR resistance of thermoelectric Heat Flux Sensor.

You can also use the Datalogger DX8140 series developed for the HF03 series of Heat Flux Sensors.

10.4 Example

Heat Flux Sensor type HFD03-128-05L12 was obtained with Specification where were listed the following:

Dimensions	- 12x12 mm ²
Number of pellet pairs	- 128
Seebeck coefficient, α	- 410 (at 300K), $\mu\text{V/K}$

The measurements of thermoelectric performance parameters according to scheme in Fig 10.1 with use of Z-Meter DX4090 (<http://PLEngineeringLtd.ru/products/devices/testers/zmeters/>) gives the following:

Figure-of-Merit, Z - $1.80 \times 10^{-3} \text{ K}^{-1}$

ACR - 14.2 Ohm

Both are referred to $T_0=300\text{K}$.

According to formulas (10.3) and (10.4)

$$S_a = \frac{1}{a \times N} Z \times ACR = \frac{2.30 \times 10^{-3} \times 14.2}{410 \times 10^{-6} \times 128} = 0.62 \text{ V/W}$$

$$S_e = S_a \times S = 0.62 \times 12^2 \times 10^{-6} = 89.6 \mu\text{V/W}$$

The calibration results are close to the Sensor standard Specification (Chapter 2).

11. MAINTENANCE OF THE SENSOR

11.1 Removing Sensor from measurement setup

If the HF03 Heat Flux Sensor has been mounted using a thermally conductive tape or paste, it can be easily removed without destroying the Sensor. The thermally conductive tape and thermally conductive paste can be removed following the instructions given in Section 4.1.

11.2 Cleaning of Sensor

Cleaning is only necessary before mounting the Sensor. Clean the Sensor surface with ethanol or isopropanol. Once the Sensor is mounted, no further cleaning is necessary.

11.3 Storage

Store an unused HF03 Heat Flux Sensor at ambient temperature in a clean and dry place. No further care is required.

12. ADDITIONAL INFORMATION

12.1 Electromagnetic field

Due to the very low electrical resistance of the Sensor the output signal is resistant to electromagnetic interference.

In most cases, no countermeasures are necessary.

If electromagnetic interference is a problem, typical countermeasures (e.g. shielded cables, grounding) have to be taken.

12.2 Trouble shooting electrical problem

In case of electrical problems, check all the connections and cables. Check for loose connections and/or short circuits in the leads.

In some cases, corroded cables are the issue. If the problem cannot be located in the leads/cables, the Sensor may be broken and has to be replaced.

12.3 Application in temperatures outside of calibration range

The calibration temperature range of the HF03 Heat Flux Sensors is stated in the respective data sheets.

Within this temperature range, PL ENGINEERING guarantees measurement accuracy better than +/- 3%.

Outside of this range, the relative error may exceed this value.

12.4 Influence of radiative heat flux

Electromagnetic radiation from deep ultraviolet wavelengths to infrared may interfere with your measurement. To achieve highest precision make sure to block off this radiation.

12.5 Use in fluids

The Sensor is hermetically sealed and may be exposed to moisture or clean neutral water at temperatures less than 100° C for a short time by properly

insulating all electrical parts. However, long term exposure to wet ambient conditions is not recommended as this may corrode the metallic leads.

Use in other fluids is not recommended.

In any case, do not expose the Sensor to strong acids or alkalis.

13. DEFINITIONS

Value	Units	Name
P_e	W/m ²	Heat flux density
P_a	W	Integral (total) heat flux to Sensor
S_e	μV/(W/m ²)	Sensitivity of Heat Flux Sensor
S_a	V/W	Integral sensitivity
D^*	cmHz ^{1/2} /W	Detectivity
NEP	W/Hz ^{1/2}	Noise equivalent power
R_T	K/W or K/(W/m ²)	Thermal resistance
α	μV/K	Seebeck coefficient
ACR	Ohm	AC resistance of Sensor
N		Number of pellets (thermoelements) pairs
ΔT	K	Operation temperature difference
T_h	K	Hot side temperature
T_c	K	Cold side temperature
K_T	W/K	Thermal conductance
k	W/mK	Thermal conductivity
s	mm ²	Cross-section of pellet
h	mm	Height of pellet
H	mm	Sensor thickness
AxB	mm ²	Sensor size (or diameter if “Dia”)
τ	s	Thermal time constant
Z	K ⁻¹	Thermoelectric Figure-of-Merit
ϵ		Emissivity of sensitive surface





PL Engineering Ltd.
46 Warshavskoe shosse, Moscow
115230 Russia
phone: +7-499-678-32-31
e-mail: info@promln.com
www.promln.com

European office: **TEC Microsystems GmbH**
Schwarzschildstr. 8, 12489 Berlin,
Germany
phone +49 (030)6789 3314
e-mail info@tec-microsystems.com
www.tec-microsystems.com